

FlexChassis ATCA-SH60 User Manual

Document: CC08102-03

9450 Carroll Park Drive
San Diego, CA 92121-2256
858-882-8800
www.ccpu.com



FlexChassis ATCA-SH60 User Manual

Document: CC08102-03

9450 Carroll Park Drive
San Diego, CA 92121-2256
858-882-8800
www.ccpu.com



© 2001-2010 Continuous Computing Corporation. All rights reserved.

The information contained in this document is provided “as is” without any express representations of warranties. In addition, Continuous Computing Corporation disclaims all implied representations and warranties, including any warranty of merchantability, fitness for a particular purpose, or non-infringement of third party intellectual property rights.

This document contains proprietary information of Continuous Computing Corporation or under license from third parties. No part of this document may be reproduced in any form or by any means or transferred to any third party without the prior written consent of Continuous Computing Corporation.

Continuous Computing, the Continuous Computing logo, Flex21, upSuite, upDisk, and upBeat are trademarks or registered trademarks of the Continuous Computing Corporation or its affiliates. All other product names mentioned herein are trademarks or registered trademarks of their respective owners. The products described in this document maybe protected by U.S. patents, foreign patents, or pending applications. No part of this publication may be reproduced, stored in a retrieval system or transmitted, in any form or by any means, photocopying, recording or otherwise, without prior written consent of Continuous Computing Corporation. No patent liability is assumed with respect to the use of the information contained herein. While every precaution has been taken in the preparation of this publication, Continuous Computing Corporation assumes no responsibility for errors or omissions. This publication and features described herein are subject to change without notice.

The information contained in this document is not designed or intended for use in human life support systems, on-line control of aircraft, aircraft navigation or aircraft communications; or in the design, construction, operation or maintenance of any nuclear facility. Continuous Computing Corporation disclaims any express or implied warranty of fitness for such uses.

Table of Contents

Table of Figures	5
Safety Instructions	6
About this Document	8
1 Introduction	9
1.1 FlexChassis ATCA-SH60.....	9
1.2 Part Number.....	9
2 Understanding the Shelf Components	10
2.1 Platform Components	10
2.1.1 Shelf and Boards	10
2.1.2 Card Cage.....	13
2.1.3 Backplane	14
2.1.4 Module Slot Identification.....	17
2.1.5 AC Power Supply.....	17
2.1.6 PEM	18
2.1.7 Fan Trays.....	20
2.1.8 Air Filter Tray	21
2.1.9 Blank Panels with/without air baffles.....	21
2.1.10 Shelf ID Board.....	22
2.1.11 Holder for Cable Management (Optional)	23
2.1.12 Shelf Manager Board	23
2.2 Shelf Cooling.....	24
2.2.1 Overview	24
2.2.2 Fan Tray Design	24
2.2.3 Performance	24
2.2.4 Fan Speed	25
3 Installing the Shelf	26
3.1 Tools Required.....	26
3.2 Site Planning.....	26
3.3 Checking Package Contents.....	27
3.4 Installation Steps.....	27
3.5 Rack Mounting	27
3.6 Shelf Grounding	27
3.7 Installer Grounding.....	28
3.8 Shelf Power-Up.....	28
3.9 Shelf Third-party Application Card Insertion	29
3.10 Shelf Management Card insertion	29
4 Maintenance And Troubleshooting	30
4.1 Performing Periodic Maintenance.....	30
4.1.1 Fan Tray Visual Inspection	30
4.1.2 Air Filter Cleaning and Replacement	30
4.2 Handling Electromagnetic Interference.....	31
4.3 Extracting/Inserting Modules.....	31
4.3.1 Third Party Board Insertion	31
4.3.2 Third Party Board Extraction	31
4.3.3 Shelf Manager Board Insertion	32
4.3.4 Shelf Manager Board Extraction	32
4.3.5 Power Supply Insertion	32
4.3.6 Power Supply Extraction.....	32
4.3.7 PEM Insertion	32
4.3.8 PEM Extraction	33
4.3.9 Fan Tray Replacement	33
4.3.10 E ² PROM Replacement	33
4.4 Handling Alarms.....	34

4.4.1 Visual Alarms	34
4.4.2 Software Alarms.....	35
4.5 Hot-Swapping FRUs	35
4.6 Resetting the System.....	36
4.7 Troubleshooting	36
5 System Specifications.....	37
5.1 Certification	37
5.2 Technical Data	38
5.3 Acronyms Used in this Manual	39

Table of Figures

I.D.	Figure	Page
1	Shelf Block Diagram	11
2	Shelf Front view	11
3	Shelf Rear View	12
4	Shelf Chassis with Cable Holders	12
5	Shelf Component Positioning	13
6	Base interface channel	15
7	Synchronization clock and update channel pin assignments	15
8	Backplane Layout	16
9	Slot Allocations	17
10	Shelf Addressing	17
11	ATCA 1500W AC Power Supply	18
12	ATCA DC PEM	19
13	Distribution of Power on Shelf	20
14	Fan Tray	21
15	Air Filter Tray	21
16	Blank Board Panel and Blank RTM Panel	22
17	Shelf ID Board with two E ² PROMs (rear cover removed)	23
18	Fan and Air Filter Trays	24
19	Rear grounding screws	28
20	Front ESD Socket	28
21	Shelf Air filter Extraction and Power supply air filter extraction	31
22	Shelf fan tray extraction	33
23	General LEDs	34
24	Telco Alarm LEDs	34
25	LEDs status when Shelf Manager boot-up completely	35
26	Application-defined LEDs	35

Safety Instructions



This symbol indicates potential safety hazards regarding product operation or maintenance to operator or service personnel.

General Safety Practices

Before handling the board, read the instructions and safety guidelines on the following pages to prevent damage to the product and to ensure your own personal safety.

- Always use caution when handling/operating the board. Only qualified, experienced, authorized electronics service personnel should access the interior of the equipment. The power supplies produce high voltages and energy hazards, which can cause bodily harm.
- Use extreme caution when installing or removing components. Refer to the installation instructions in this document for precautions and procedures. If you have any questions, please contact Technical Support.
- Always follow the procedural instructions for component removal and replacement in sequence.

Power



Beware Electrical shock hazard before any attempt to service the device be sure that the device is electrically isolated!!!

High voltages are present inside the chassis when the unit's power is plugged into an electrical outlet. Turn off system power, turn off the power supply, and then disconnect the power cord from its source before removing the chassis cover.

Turning off the system power switch does not remove power to components.

Make sure the work environment is grounded, and use a grounding wrist strap when handling the product.

ESD Safety Practices

Many components described in this document can be damaged by electrostatic discharge (ESD). Follow the precautions described here and before specific procedures in the document to protect static-sensitive components from ESD-related damage.

Static electricity can harm system boards. Perform service at an ESD workstation and follow proper ESD procedure to reduce the risk of damage to components. It is encouraged to follow proper ESD procedure, which can include wrist straps and smocks, when servicing equipment.

Take the following steps to prevent damage from electrostatic discharge (ESD):

- When unpacking a static-sensitive component from its shipping carton, do not remove the component's antistatic packing material until you are ready to install the component in the system. Just before unwrapping the antistatic packaging, be sure you are at an ESD workstation or grounded. This will discharge any static electricity that may have built up in your body.
- When transporting a sensitive component, first place it in an antistatic container or packaging.
- Handle all sensitive components at an ESD workstation. If possible, use antistatic floor

pads and workbench pads.

- Handle components and boards with care. Don't touch the components or contacts on a board. Hold a board by its edges or by its metal mounting bracket.
- Do not handle or store system boards near strong electrostatic, electromagnetic, magnetic, or radioactive fields.

About this Document

This document provides technical information for the FlexChassis ATCA-SH60.

It is intended for technical staff tasked with installing, setting up and configuring the system, and providing troubleshooting assistance and servicing.



Related Documents

For information on the Shelf Manager, see the Continuous Computing Shelf Manager Carrier Board user manual.

Instructions relating to software installation and documentation for application software development for this platform are available in the Shelf Manager External Interface Reference Manual.

Information about PICMG (PCI Industrial Computer Manufacturers Group) and the ATCA standard may be accessed on the PICMG Web site at <http://www.picmg.com>.

Style Conventions

<hr/> Verdana	Regular text.
<hr/> Arial Bold	Commands, keys and other parts of the user interface.
<hr/> <i>Arial Italics</i>	Names of classes, methods, arguments, exceptions, properties, etc. Also used for special terms, the first time they appear.
<hr/> Monospace	Text displayed on the LCD or on a computer attached to the product.
<hr/> 	Notes, which offer an additional explanation or a hint on how to overcome a common problem.
<hr/> 	Warnings, which indicate potential safety hazards regarding product operation or maintenance to operator or service personnel.

1 Introduction

This chapter includes a summary of the FlexChassis ATCA-SH60. For acronyms used in this document see Section 5.3.

1.1 FlexChassis ATCA-SH60

The FlexChassis ATCA-SH60 offers the reliability and availability of the Telco-grade standards in a cost-effective package, where maximum possible performance (backplane interconnect bandwidth, power levels and thermal capabilities) is provided in a low-cost shelf.

The FlexChassis ATCA-SH60 has been developed based on the accumulated knowledge and experience in the implementation of the ATCA standard since its inception in 2001, while incorporating the latest technologies available. It incorporates the latest technologies available to reduce its price while maintaining performance and reliability.

The system offers optional redundancy for power input and management functions.

The system can be used by developers (reduced time-to-market) as well as for deployment. It offers optional redundancy for power input and management functions (see Section 2.1.5). All shelf assemblies are designed using Field-Replaceable Units (FRUs), thus enabling easy and fast field maintenance with minimum or no downtime, availability of 99.999%.

In addition, a cable-holder frame can be fitted to both side-mounting flanges of the shelf (see Section 2.1.10).

The FlexChassis ATCA-SH60 is designed to comply with FCC and CE certification, and with UL, NEBS Level-3 and ETSI.

The FlexChassis SH-60 fully complies to AdvancedTCA, PICMG 3.0 R2.0, and IPMI v 1.5.

See Section 5.2 for detailed system specifications.

1.2 Part Number

Part Number	Module
5-02917	FlexChassis ATCA-SH60 19", 6U, 6-slot shelf w/ dual star base interface and dual fan trays; designed to accommodate (but does not include) 3x AC PSUs or 2x rear PEMs.

2 Understanding the Shelf Components

This chapter summarizes the functional features of the FlexChassis ATCA-SH60, and describes in further detail each of the components as well as the shelf system cooling mechanism.

The system was designed to withstand extreme conditions (to meet rigid Telco requirements). It is designed to incorporate Field-Replaceable Units (FRUs), and is fully field-serviceable.

2.1 Platform Components

A typical platform consists of the following key components:

- **19-inch rack mount shelf** — Base hardware element of the platform, which holds all the components together.
- **Card cage** — Portion of the shelf that holds the modules that are plugged into the backplane. Mechanically compliant with all aspects of PIMG 3.0.
- **Backplane** — Supports one to six third-party ATCA-compliant front boards, and the complementary rear transition module (RTM). The backplane provides dual star Fabric interface, and direct mating to the Power Supplies and to the redundant Shelf Manager Boards.
- **Power Supply (PS)** - Up to three Redundant, field replaceable, 100 VAC to 240 VAC, power supplies.
- **PEM (Power Entry Module)** — Dual redundant and hot swappable Power Entry Modules.
- **Fan tray** — Dual Redundant push-pull fan trays. Hot-swappable, provides side to side cooling, and is designed to provide full redundancy cooling to components on the front and rear of the shelf.
- **Air filter tray** — Keeps the airflow free of dust and particles.
- **Blank Panels** — For air flow management.
- **Shelf ID Board (E²prom)** – Contains the shelf identification information.
- **Cable management** - Holders for Front cable management.

2.1.1 Shelf and Boards

Figure 1 shows the block diagram of the shelf and *figures 2* and *3* show front and rear views of the shelf with key components highlighted.

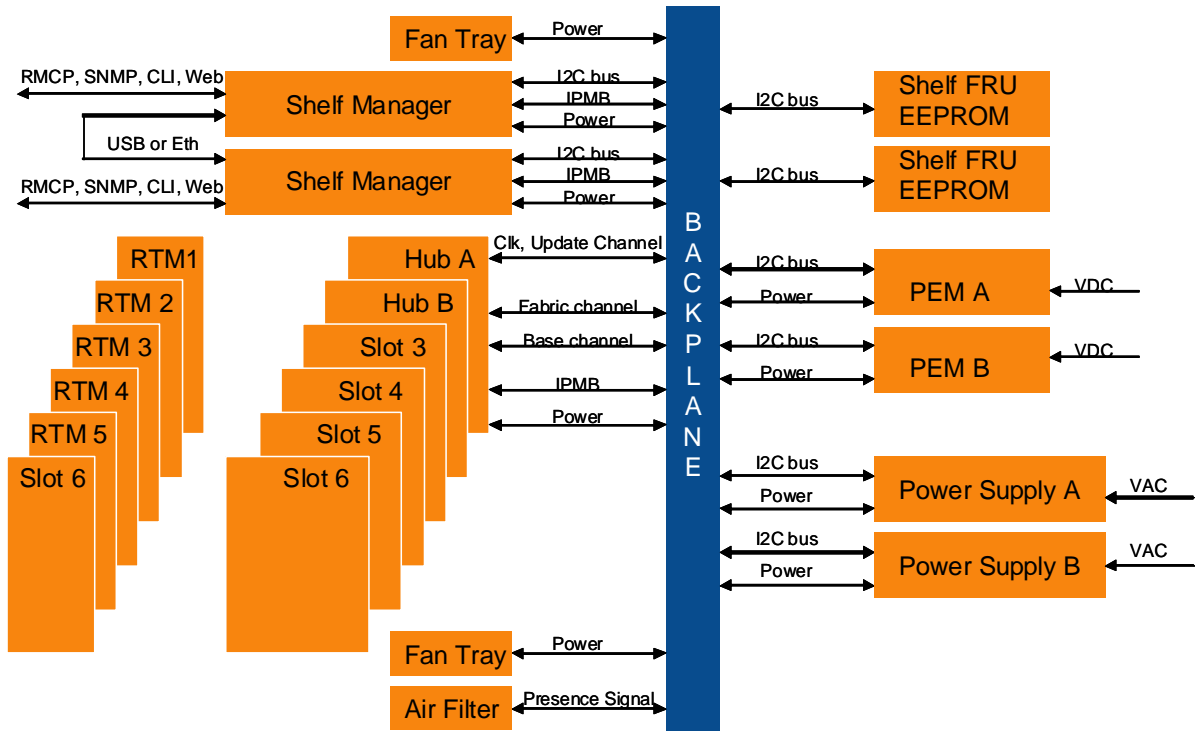

Figure 1 – Shelf Block Diagram

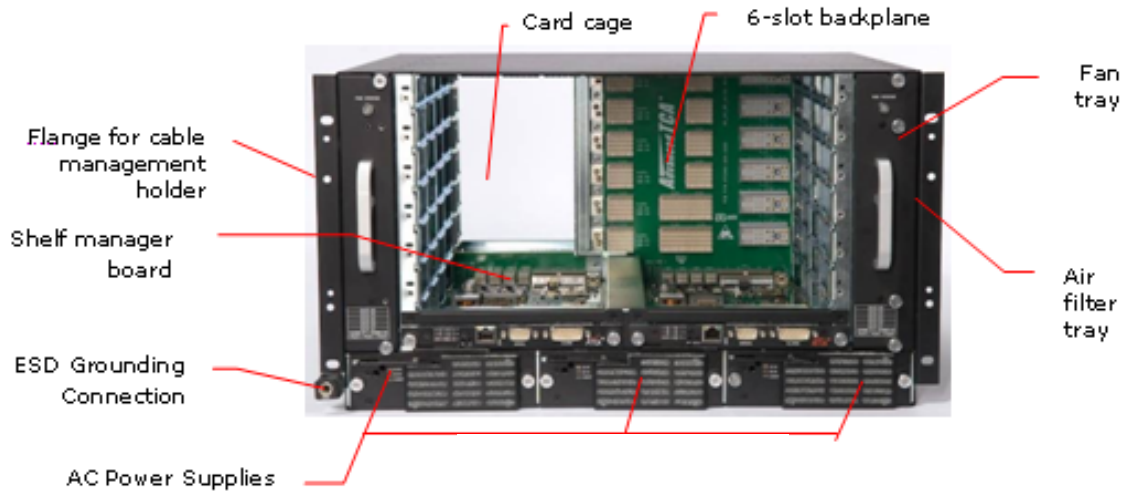

Figure 2 – Shelf Front View

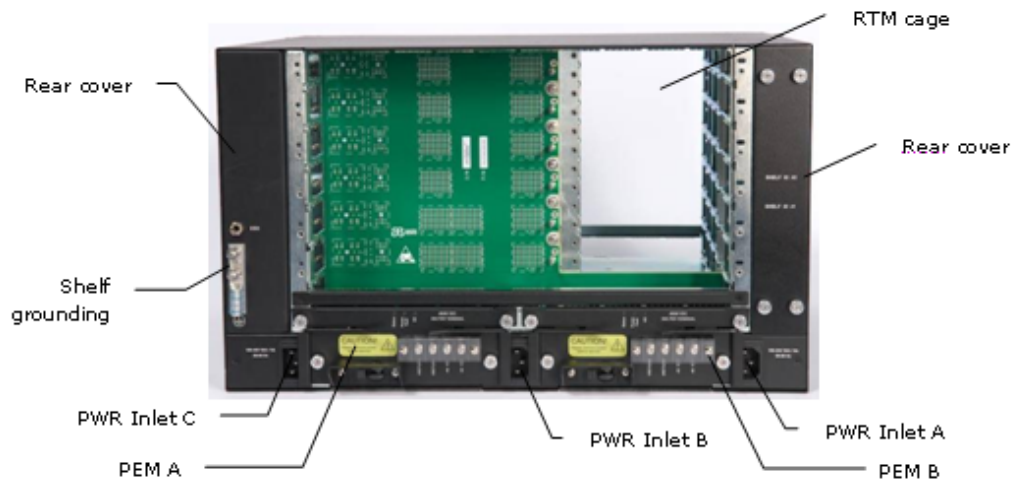

Figure 3 – Shelf Rear View

Figure 4 illustrates the use of cable holders:

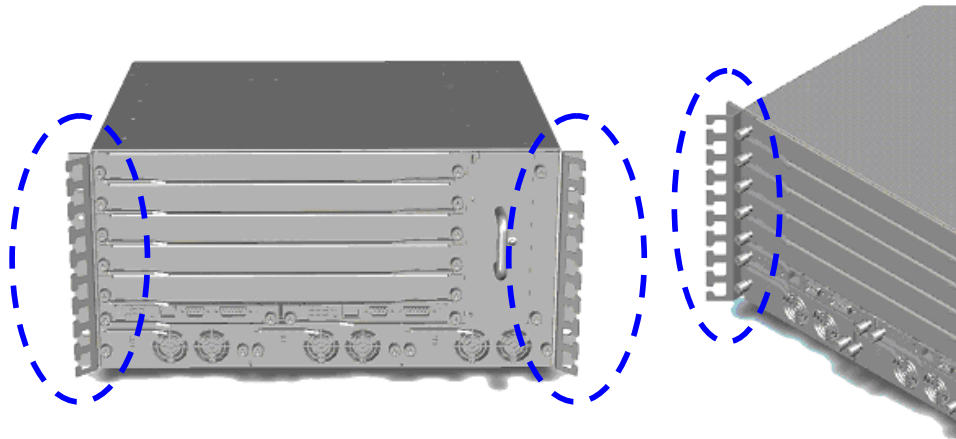

Figure 4 – Shelf Chassis with Cable Holders



Figure 5 - Shelf Component Positioning

In order to increase FlexChassis ATCA-SH60 reliability, and to simplify the shelf's format, most of the shelf logic is located in a one location, the shelf manager. Most of the other boards and FRU's are passive.

Only the backplane is a fixed board. Remaining boards are removable:

Fixed Board

- Backplane

Removable Boards

- Shelf Manager Board boards (see the Shelf Manager Carrier Board User Manual).
- Shelf ID board: this board hosts two E²PROMs that contain data about the shelf – such as serial number and manufacturer – and about the board's setup – such as shelf thermal budget and slot population.
- Power Supplies
- Power Entry Modules
- Fan Trays
- Air Filter

2.1.2 Card Cage

The shelf's card cage is composed of:

- The backplane
- Right and left guide rails to hold the modules that plug into the backplane.

The card cage supports six 8U front boards, and six 8U RTMs.

The guide rails in the card cage incorporate electrostatic discharge (ESD) clips.

2.1.3 Backplane

Features

The ATCA PICMG 3.0-compliant backplane provides interconnectivity between the FRU's and shelf's front blade connectivity. It conforms to the *PICMG 3.0 R2.0 AdvancedTCA Base Specification*.

Backplane features include:

- Six slots
- Fabric interface with dual star
- The Fabric Interface grid consists of eight differential pairs per channel; The Base Interface grid consists of four differential pairs per channel.
- Dual-star Ethernet signaling environment on the Base interface
- Bussed IPMI
- Hub slots are slots 1&2
- Update channel between slots 1&2 and 3&4 and 5&6
- 10, 100 and 1000 BASE-T dual star Base Interconnect capability. Update-channel interfaces for active and standby synchronization, and mesh topology handling 3.125Gbps per differential pair.
- Connection capacity for up to six third-party ATCA-compliant front boards, as well as to the redundant Shelf Manager Board and redundant Power Supply units.
- Full compliance with AdvancedTCA™ electrical and mechanical specifications
- Interconnect for system power for six slots.
- Base Interface Channel 1 of Logical Slot 1 is routed to the left dedicated
- Shelf Manager slot on the ATCA Backplane. Base Interface Channel 1 of Logical Slot 2 is routed to the right dedicated Shelf Manager slot on the ATCA Backplane.

There are no active components on the backplane, and no removable or serviceable parts on the backplane board.

The backplane has two functionally-distinct parts: right and center left:

- Right backplane (consists of Zone 1 connectors) – dual-power connections, which means the power connections from the Power supplies are independently supplied to each module plugged into the backplane. The modules also include fuses that protect the backplane power connections from an electrical short on a module.
- Center left backplane (consists of Zone 2 connectors) – connectivity for the Base, Fabric, and update-channel interface. This portion supports a dual star or full-mesh topology for both the Base and the Fabric interfaces.

Update-Channel Connections

The update channels are backplane connections between pairs of modules that operate on a redundant basis. Application software can use the update channel for redundancy interlock, or to provide a direct connection that bypasses the (indirect) fabric interface.

If you configure a pair of modules to use the update channel for redundancy support, you must insert the two modules into slots linked by an update channel.

Figure 7 shows the update channel connections.

Each update channel consists of 10 differential-pair connections. If an update channel connects two modules that are not identical, the Shelf Manager disables the update channel between them.

Base interface

The Base interface comprised of a single row of signal pins for a total of four signal pairs per Base interface. In total the Base interface contains 6 Base channels for a total of 20 possible signal pairs per board/slot. A Base channel can be used to support a 10/100/1000BASE-T Port comprised of four signal pairs.

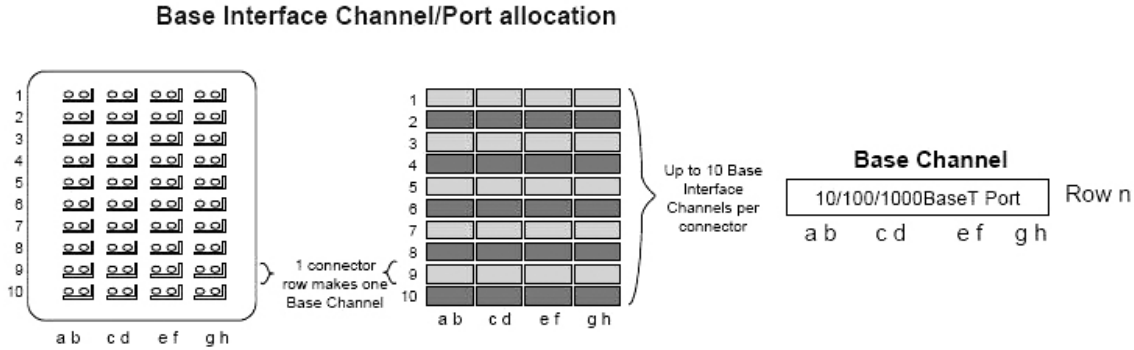

Figure 6 - Base interface channel

Fabric interface

The Fabric Interface allocates signal pairs differently than the Base Interface. A Fabric Channel is comprised of two rows of signal pairs for a total of eight signal pairs per Channel. Thus, each connector supports up to six channels available for Board to Board connectivity. A Channel may also be viewed as being comprised of four 2-pair Ports.

Synchronization Clock Interface

The backplane supports a set of synchronization clock buses that can exchange synchronization timing information. This synchronization can be used for system-wide and intersystem synchronization purposes, which are important in some applications, such as those involving synchronous time division multiplex (TDM).

Row #	Interface	Px20 Connector Pairs							
		ab		cd		ef		gh	
1	Clks	CLK1A+	CLK1A-	CLK1B+	CLK1B-	CLK2A+	CLK2A-	CLK2B+	CLK2B-
2	Update channel & Clks	Tx4(UP)+	Tx4(UP)-	Rx4(UP)+	Rx4(UP)-	CLK3A+	CLK3A-	CLK3B+	CLK3B-
3		Tx2(UP)+	Tx2(UP)-	Rx2(UP)+	Rx2(UP)-	Tx3(UP)+	Tx3(UP)-	Rx3(UP)+	Rx3(UP)-
4		Tx0(UP)+	Tx0(UP)-	Rx0(UP)+	Rx0(UP)-	Tx1(UP)+	Tx1(UP)-	Rx1(UP)+	Rx1(UP)-
The update channels are routed to adjacent slots. Slot 1 connects to Slot 2, Slot 3 connects to Slot 4 and Slot 5 connects to Slot 6.									

Figure 7 – Synchronization clock and update channel pin assignments

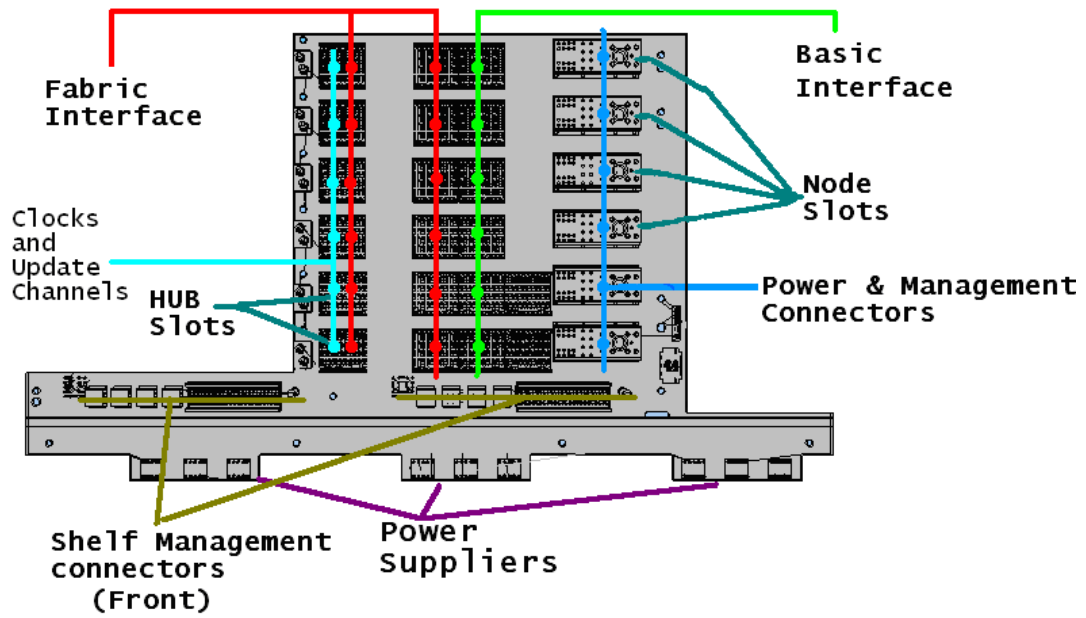

Figure 8 - Backplane Layout

2.1.4 Module Slot Identification

The shelf is compliant with PICMG 3.0 R2.0, and accepts modules compliant with this standard.

Figure 9 illustrates the locations of the module slot allocations when viewed from the front. The physical and the logical slot allocations are the same for this shelf: the slots are numbered 1 to 6 from bottom to top.

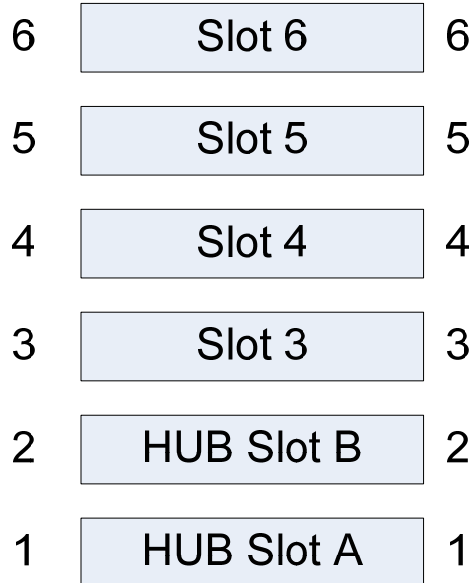

Figure 9 – Slot Allocations

The following table shows the hardware addresses in relation to the slot numbers and slot addresses. Slots are shown in the same order as they appear in the shelf: slot 2 above slot 1.

Slot Number	Hardware Address (8 bit format)	Hardware Address (7 bit format)
6	8Ch	46h
5	8Ah	45h
4	88h	44h
3	86h	43h
2	84h	42h
1	82h	41h

Figure 10 - Shelf Addressing

2.1.5 AC Power Supply

The field replaceable and hot swappable, 100 VAC to 240 VAC, power supplies are providing power to the shelf.

The FlexChassis ATCA-SH60 is equipped with AC power inlets which are located in the rear for redundancy. Each power supply is capable of supplying 1500W. One power supply is fully capable of supplying the power

consumed by a fully occupied shelf. The use of the second and third power supply is for cases where redundancy and/or additional power are needed.

The three power supplies are located in the lower part of the shelf. Each power supply has its own front-back independent cooling. In order to comply with NEBS GR63 Core the power supplies have separate removable air filters.

The air filters should be cleaned or replaced every three to six months. They can be cleaned with slightly compressed air, vacuumed, and/or rinsed with clean water. If a degreaser is required, use only a mild detergent, such as, dishwashing liquid. Avoid using harsh solvents or cleaning agents. Even though this type of filter may be cleaned, replacement is recommended every two to three years to ensure durability and eliminate residual dust build-up and subsequent air flow resistance.

The AC inlet connectors are located on the rear of the shelf.

Please use a power cord with the following rating:

Rated for 250 volt, 15/10 amp, 2 poles, 3 wire. Connector can be terminated to 14 thru 16 AWG (gauge) cord only. UL, CSA, VDE approved.

Female Connector IEC 60320 C13 on one end and your standard domestic AC power plug that fit's your wall AC sockets on the other end.



Figure 11 - ATCA 1500W AC Power Supply

Note – Do not use power supplies and PEM simultaneously. In case of using an AC source, plug the power supplies in and remove the PEMs. In case of DC source, plug in the PEMs and remove the power supplies.

Grounding Requirements and Power Input



When connecting ground and power cables to the shelf, follow instructions in the beginning of this document.

2.1.6 PEM

The field replaceable, -48 VDC, PEMs provide power to the shelf.

The FlexChassis ATCA-SH60 is equipped with connectors for two redundant - hot swappable and field replaceable PEMs.

Both PEMs are located in the lower-Back of the shelf, fitting directly into to the backplane.

The DC connectors are located on the rear of the chassis.

Each PEM is equipped with a 50 Amps circuit breaker.
For DC connectors, the minimum nominal diameter of terminal block need be more than 6.0mm.
The thread size of the DC connection bolts/lugs is M4.



Figure 12 - ATCA DC PEM

Note – Do not use power supplies and PEM simultaneously. In case of using an AC source, plug the power supplies in and remove the PEMs. In case of DC source, plug in the PEMs and remove the power supplies.

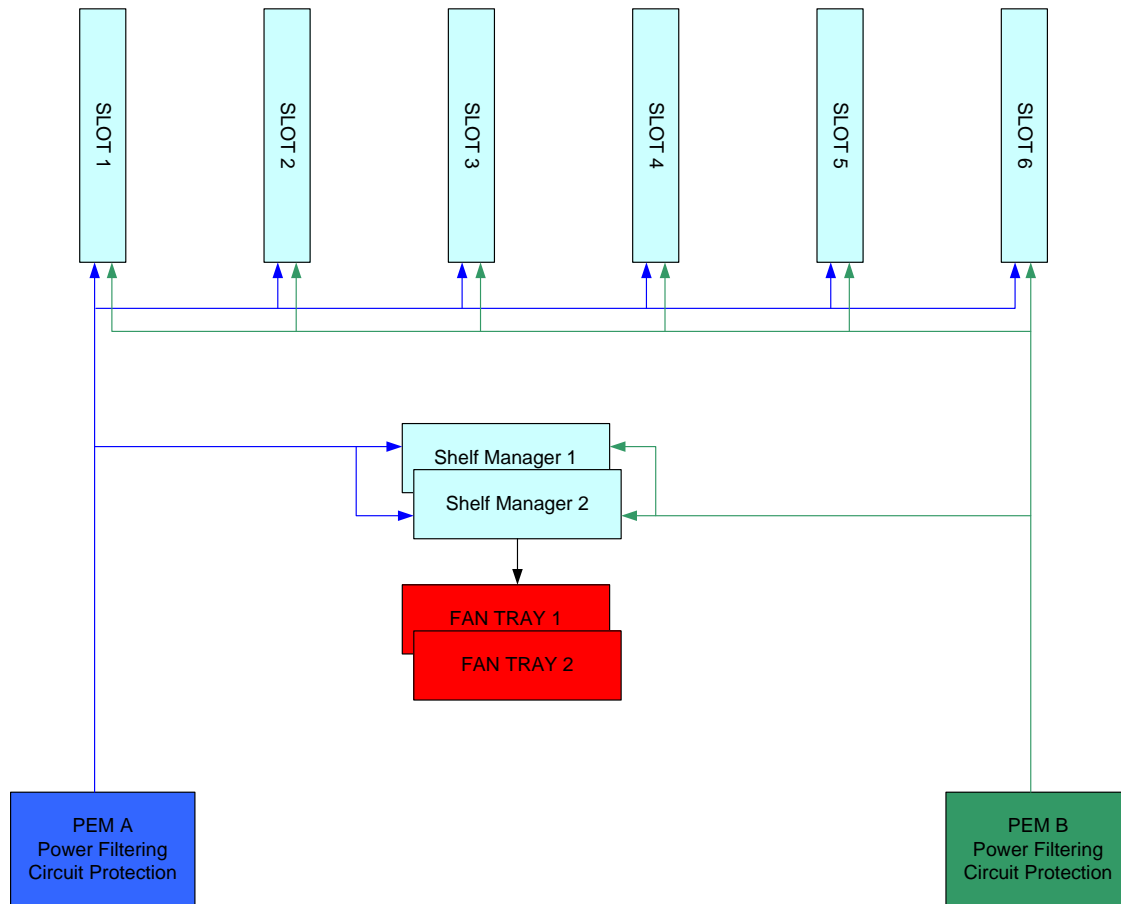

Figure 13 - Distribution of Power on Shelf

Grounding Requirements and Power Input



When connecting ground and power cables to the shelf, follow instructions in the beginning of this document.

2.1.7 Fan Trays

Each fan tray is a closed module containing six 92x92mm fans and four 40x40mm fans that supply air volume and velocity for cooling the high-density/high-performance computing environment (see Figure 14). The cooling power of the fan tray can dissipate the heat generated by up to six front boards and complementary RTMs.

A total bulk airflow of 548cfm is supported.

Six of the fans are dedicated to cooling the front side of the shelf, while four are cooling the rear side Boards.

The two fan trays are designed full redundancy to meet the cooling requirements of a full shelf in the most demanding situations.

In case of single fan failure, the other fan tray in addition to the remaining fans in the same tray will provide the required cooling to dissipate the heat generated by the occupied slots. If a failure occurs, it is recommended to replace a fan tray as soon as possible.

Both fan trays are factory-mounted in the FlexChassis ATCA-SH60. They are easily replaceable, and can be replaced while the shelf is operating.

For more on shelf cooling, see Section 2.2.



Figure 14 – Fan Tray

2.1.8 Air Filter Tray

A NEBS-GR63-compatible air filter comes installed on the FlexChassis ATCA-SH60. The filter is field-serviceable, and can be extracted for periodic field maintenance or for field replacement.

The filter is easily accessible from front right side of the card cage.

For instructions on air-filter maintenance, see Section 4.1.2.

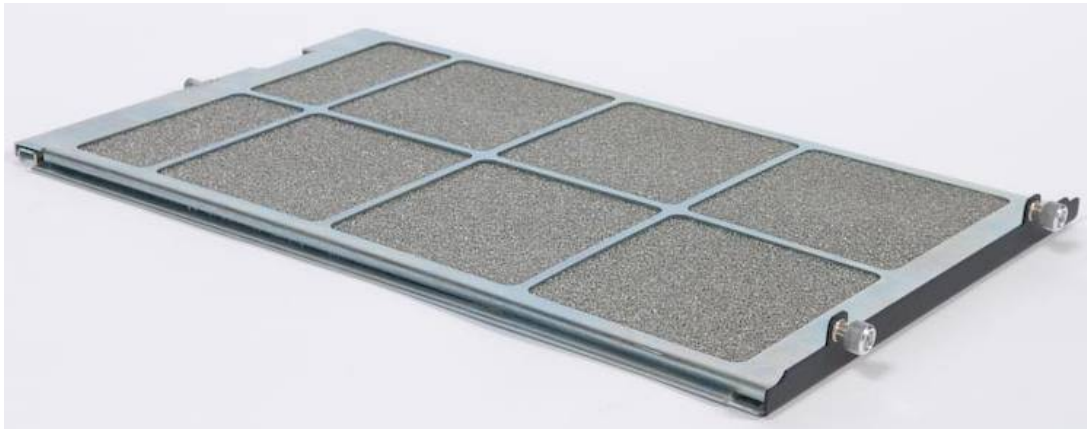

Figure 15 – Air filter tray

2.1.9 Blank Panels with/without air baffles

Compliance with ATCA's temperature specifications requires a steady air flow in the shelf. To insure a steady air

flow, either the FlexChassis ATCA-SH60 must be fully populated, or a blank panel must be equipped to fill every empty slot.

The "blank panel" is designed to emulate the air flow restriction in a standard card, thus ensuring the required conditions for proper cooling.

Three types of airflow-management panels are available for the empty slots on the shelf. These include panels specifically designed for:

- Blank front module panels, with/without air baffle;
- Blank RTM panels;
- An empty shelf-manager panel slot.



Figure 16 - Blank Board Panel and Blank RTM Panel

2.1.10 Shelf ID Board

A shelf ID board containing two redundant field replaceable E²PROM chips is housed in the rear of the FlexChassis ATCA-SH60.

The E²PROMs store product and manufacturer information such as shelf serial number, part number, backplane routing assignment, and shelf heat budget.

When the Shelf Manager board boots up, it compares the information stored in the two E²PROMs:

- If E²PROM data coincides, it is loaded and saved in the Shelf Manager Board, and the shelf initializes.
- In case of a mismatch, the data on the E²PROMs is compared with the last saved configuration in the ShMM Board:
 - If the saved configuration matches one of the E²PROMs it is assumed to be the right one and it is stored in both E²PROMs.
 - If the three configurations are all different, the Shelf Manager board will not boot up.

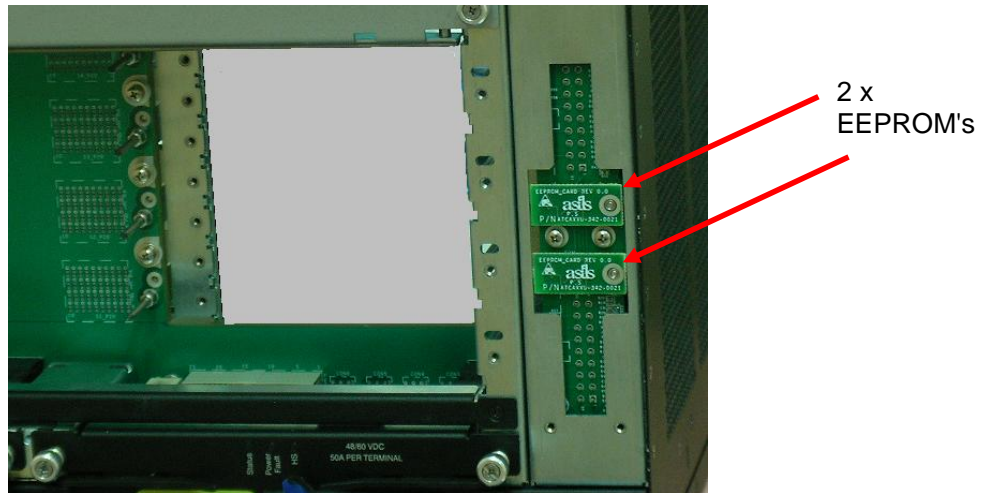

Figure 17 - Shelf ID Board with two EEPROMs (rear cover removed)

2.1.11 Holder for Cable Management (Optional)

A cable holder frame can be fitted to both side mounting flanges of the shelf.

Please note that since there are fan trays on both sides of the shelf, it might be difficult to replace a fan tray due to cabling that are bring routed from the sides. Take it into account while you route the wires and cables to and from the shelf.



Cables attached to the cable management holder must be allowed to move freely; Insure that a service loop of minimal required length is maintained.

2.1.12 Shelf Manager Board

The shelf manager controls and manages the chassis. It controls the fans speed, monitors temperatures across the chassis, manages the hot swap insertion and extraction of modules and blades and performs multiple other tasks and functionalities. For more information, please refer to the separate Shelf Management Board user manual.

2.2 Shelf Cooling

2.2.1 Overview

FlexChassis ATCA-SH60 complies with all the cooling requirements specified in PICMG V3.x specifications.

The cooling system consists of twenty high-performance fans (ten per fan tray). The air comes in from the right side and exits through the left side of the shelf. The fault-tolerant design is optimized for total bulk airflow of 548cfm.

2.2.2 Fan Tray Design

FlexChassis ATCA-SH60 ventilation is achieved using a push pull scheme. Each fan tray contains six 92mmx92mm fans for front card cooling and four 40mmx40mm fans for RTM cooling.



Figure 18 – Fan and Air filter trays

The fan tray connects directly to the backplane, there it plugs into power and control connectors. The fan tray unit is front-serviceable, and can be easily replaced without tools.

In order to minimize possible failures, the fan tray does not contain any active electronic components. The shelf management or fan tray redundancy board FRU fully controls adjustments of the fans based on temperature changes.

Cooling ability is maintained even in the case of a single fan failure. In this case, the green LED of the fan tray turns red, so that it is easier to identify the tray that needs to be replaced.

2.2.3 Performance

The twenty fans supply air volume and velocity for cooling the high-density/high-performance computing environment. The cooling power of the fans can dissipate the heat generated by up to six front boards and complementary RTMs. A total bulk airflow of 548cfm is supported.



Refrain from clogging air input and exhaust during chassis operation.

2.2.4 Fan Speed

If the shelf is initialized and the fan tray is inserted right after power up, the fans start at full speed and then decrease by steps of 7%. Under normal operating conditions, the fans run at 21% of full speed. The lower speed reduces the acoustic noise and increases the longevity of the fans. The circuitry on the fan trays uses a Pulse-Width Modulation to control the speed of the fans.

When a fan tray is inserted into the shelf, during normal operation the shelf manager checks the temperature sensor and according to the temperature, it decides whether to increase the fans speed or stay at current level.

The speed of each individual fan is monitored. If the speed of any of the fans drops below the desired fan speed, the other fans will speed up to compensate. The Shelf Manager logs such events in its system event log (SEL) as a fault condition. If this occurs, replace the fan tray as soon as possible to restore fault tolerance and redundancy.

3 Installing the Shelf

This chapter provides you with instructions on how to prepare the FlexChassis ATCA-SH60 for use. You will be performing some or all of the following setup tasks:

- Site Planning
- Checking Package Contents
- Rack Mounting
- Shelf Grounding
- Shelf Third-party Application Card Insertion
- Shelf Manager card insertion
- Shelf Power Up



Before installing the FlexChassis ATCA-SH60, you should be aware of what cables will be needed for connectivity and power, and whether they will be connected in the front or rear of the shelf.

3.1 Tools Required

To install the shelf in a standard 19" rack, the following tools are required:

- Standard Philips screwdriver set
- Wrench
- ESD grounding bracelet.

All the modules in the FlexChassis ATCA-SH60 are field-replaceable units (FRUs) requiring no special tools for mounting other than those mentioned above.

3.2 Site Planning



Only qualified personnel should be involved with this installation procedure.

The FlexChassis ATCA-SH60 can be installed either on a standard 19" rack or as a desk-top unit. All sides of the shelf should be easily accessible.

The pre-requisites for setting up the FlexChassis ATCA-SH60 for use in your facility involves:

- If a rack is used, it should be properly grounded.
- A readily accessible disconnect device must be incorporated into the building's wiring between the shelf's power inlet inputs and the AC or DC power source.
- The disconnect device rating required is determined by the nominal input voltage.
- To ensure sufficient airflow for the individual blades in the shelf, allow at least two inches of clearance at the side air inlets and outlets.

3.3 Checking Package Contents

The following items are included in the FlexChassis ATCA-SH60 package. Check that all items in the package are intact.



Use of equipment damaged during delivery could prevent proper functioning of the Shelf and/or cause permanent damage to it. Check all pins, screws and other components before using any of the package contents.

- Shelf chassis with backplane
- Two fan trays
- Air filter tray
- One, two or three Power-Supplies (based on what was ordered)
- One or two PEMs (based on what was ordered)
- One or Two Cable-management holders (Depending on what was ordered)
- AC cable (based on what was ordered)

3.4 Installation Steps

The following overall procedure is described more in detail in the sections below.

This operation should be maintained at least by two personal.

1. Install the Cable-management tray holder (optional).
2. Mount the shelf in the rack with four screws.
3. Connect the shelf to the site ground with a ground cable.
4. Insert a Shelf Manager Carrier board into the right shelf manager slot.
5. Connect the power Cables to the power inlets at the rear of the shelf.

Note – Do not use power supplies and PEM simultaneously. In case of using an AC source, plug the power supplies in and remove the PEMs. In case of DC source, plug in the PEMs and remove the power supplies.

3.5 Rack Mounting

You will need four M6x10 (or longer) screws to mount the shelf on the rack.

Before you begin:

- Verify that the transient operating temperature in the area of the rack does not exceed the 55°C maximum.
- Confirm the rack is stable so that the weight of the shelf does not cause it to tip over.

☛To mount the shelf on the rack:

- Insert the FlexChassis ATCA-SH60 chassis on the 19" rack, securing it by fastening the four mounting screws.
- The shelf should be level, and not positioned at an angle in the rack, and the rack's doors should be able to close.

3.6 Shelf Grounding

Connect rear grounding screws on the rear left side to insure that the shelf is properly grounded.

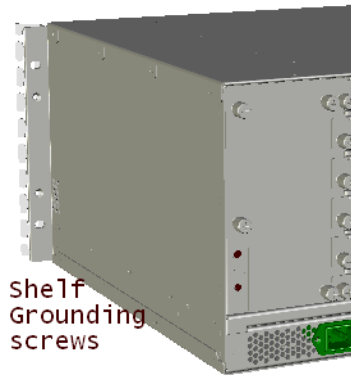

Figure 19 – Rear grounding screws

3.7 Installer Grounding



Any person involved in handling the shelf or card installation or replacement is required to wear an ESD grounding device.

One grounding socket can be found on the shelf:



Figure 20 – Front ESD Socket

3.8 Shelf Power-Up

❏ To power up the shelf:

1. Connect an AC/DC power cord between the power inlet and the power source.
2. If there are two power supplies/PEM installed, connect the second power inlet to a power source.
3. The shelf manager set the fans speed to max velocity and when it's finishes booting, it reduces the fans speed according to the temperature it gets from all the sensors in the shelf.
4. The initial state of the LEDs in the shelf Manager is red. After it finishes booting, All LEDs turn off except for the ACT and PWR LEDs which should turn green. In a case that the shelf manager is not active (i.e. Secondary shelf manager) the ACT LED will blink.

3.9 Shelf Third-party Application Card Insertion

Application cards should be inserted only after the installation, power-up and testing procedures of the FlexChassis ATCA-SH60 have been completed.

Insert application cards according to the manufacturer's instructions, making sure they are properly-positioned in their slots and are secured to their respective connectors.

When an application card is inserted and powered up, the blue LED should switch on and light steady for 10-30 seconds in general (depending on the card type). After that time, the blue LED should blink for about 10 seconds, and then go off.

Each third-party application card must provide a hot-swap LED. This LED can be in one of the following states:

Indicator State	Indication
Off	The card is not ready for removal or disconnection from the shelf
Blue	The card is ready for removal or disconnection from the shelf
Blinking slowly	The card is activating itself
Blinking quickly	Brief deactivation has been requested

3.10 Shelf Management Card insertion

Simply insert the shelf manager card into its allocated space, see section 4.3.3 . Close the two tumble screws tightly. All Shelf manager LEDs should illuminate for a period of few seconds. After a few seconds, all LEDs should turn off except for the ACT and PWR LEDs which should illuminate in green. For more details refer to the "Shelf Manager Board User Manual".

4 Maintenance And Troubleshooting

This chapter includes instructions regarding:

- Performing Periodic Maintenance
- Shelf Air filter and Power supply air filter extraction
- Handling Electromagnetic Interference
- Extracting Modules
- Handling Alarms
- Hot-Swapping FRUs
- Resetting The System
- Troubleshooting.

As required by the ATCA standard, the FlexChassis ATCA-SH60 applies a fully hot-swappable approach. Assuming redundancy has been provided for (i.e., two Shelf Mangers and two power supplies or PEMs), all of the shelf assemblies can be field-replaced with no interruption to service, when redundant is applied.

Visual alarms provide clear indication of trouble, for easy problem location.

Malfunctions can be responded to quickly and easily, as no field repair is necessary. Failed modules can be easily extracted and replaced with no tools or with a minimal set of tools.

4.1 Performing Periodic Maintenance

This section provides procedural instructions on servicing or replacing shelf components.

Maintenance of the FlexChassis ATCA-SH60 involves the following tasks:

- Fan Tray Visual Inspection
- Air Filter Cleaning and Replacement

4.1.1 Fan Tray Visual Inspection

The fan trays should be checked periodically for any visible damage that could prevent or disrupt normal fan operation.

See Section 4.3.9 for instructions on replacing a fan tray.

4.1.2 Air Filter Cleaning and Replacement

The air filter should be cleaned or replaced every three to six months. The air filter can be extracted without interrupting power. Release the two tumble screws on the front side of the air filter unit and extract the unit by pulling the two tumble screws.

Air filter cleaning must be performed in a different location from where the shelf is placed. It can be cleaned with slightly compressed air, vacuumed, and/or rinsed with clean water. If a degreaser is required, use only a mild detergent, such as, dishwashing liquid. Avoid using harsh solvents or cleaning agents.

If environmental conditions are good, it may be enough to extract the filter and clean it. Otherwise it might be necessary to replace it. Replacement is recommended every two to three years to ensure durability and eliminate residual dust build-up and subsequent air flow resistance. The air filter can be ordered separately (i.e., without the metal tray).



Figure 21 – Shelf Air filter and Power supply air filter extraction

4.2 Handling Electromagnetic Interference

The shelf emits electromagnetic waves that may interfere with nearby equipment. Conversely, nearby electronic equipment may emit electromagnetic waves that interfere with the shelf. The EMC, EMI, and RFI specifications of the shelf and all nearby equipment should be considered when choosing the placement of the platform and surrounding equipment.

In the shelf and most other equipment, the use of fillers panels in otherwise unoccupied slots is necessary to keep the product's emissions within their specified limits.

- Install front and rear airflow management fillers into any empty slots.
- Do not use blank faceplates in place of fillers.
- Keep slots populated with active modules directly next to each other and fillers directly adjacent to the outermost active modules.
- If the shelf experiences unexpected and intermittent data errors, carefully consider the possibility of electromagnetic interference from nearby equipment as a possible source of the problem.

Identifying and measuring errors caused by electromagnetic interference can be challenging and may require the assistance of engineering personnel with experience in this field.

If your system configuration does not populate all front slots with active blades, you must fill those empty slots with additional blades or slot flow blocker blades to maintain system airflow and electromagnetic shielding integrity. Blank panels can be ordered separately.

4.3 Extracting/Inserting Modules

4.3.1 Third Party Board Insertion

➔ To insert an ATCA-compliant third party board:

1. Slide the board's carefully into the shelf.
2. Push the insertion lever inward, making sure it goes fully in to the niche.
3. The blue LED should start to blink until the shelf manager confirms that it's checksum is identical to the e²proms.
4. After the module's blue led turn off (data match), the module is active.

4.3.2 Third Party Board Extraction

➔ To extract an ATCA-compliant third party board:

1. Pull the board's insertion lever slightly. The de-activation sequence begins.
2. After the board's blue LED lights steady, pull out the board's insertion lever.
3. Pull out the board.

4.3.3 Shelf Manager Board Insertion

➔ **To insert a shelf manager:**

1. Push the module's inward carefully.
2. Push the insertion lever inward, making sure it goes fully in to the niche.
3. The blue LED should start to blink until the shelf manager confirms that it's checksum is identical to the e²proms.

4.3.4 Shelf Manager Board Extraction

➔ **To extract a shelf manager:**

1. Pull the module's insertion lever slightly. The de-activation sequence begins.
2. After the module's blue LED lights steady, pull out the module's insertion lever.
3. Pull out the module.

4.3.5 Power Supply Insertion

If Power Supply redundancy is implemented, one of the Power Supply can be inserted without interfering the normal operation of the shelf.

➔ **To insert a Power supply:**

1. Push in the Power supply.
2. Fully push in the Power supply insertion lever.
3. Verify that the power supply LEDs are illuminating.
4. Tighten the two tumble screws in to place.

Note – Do not use power supplies and PEM simultaneously. In case of using an AC source, plug the power supplies in and remove the PEMs. In case of DC source, plug in the PEMs and remove the power supplies.

4.3.6 Power Supply Extraction

If Power Supply redundancy is implemented, one of the power supplies can be extracted without interfering the normal operation of the shelf.

➔ **To extract Power supply:**

1. Disconnect the power cables.
2. Release the two tumble screws on the front side of the power supply.
3. Fully pull out the power supply insertion lever.
4. Pull out the Power supply.

4.3.7 PEM Insertion

The PEM can be inserted to an operating shelf with no interference to normal operation.

➔ **To insert a PEM:**

1. Push in the PEM
2. Fully push in the PEM insertion lever.
3. Tighten the two tumble screws in to place.

4.3.8 PEM Extraction

If PEM redundancy is implemented, one of the PEM can be extracted with no interference to normal operation.

➔ **To extract one PEM:**

1. Disconnect the power cables.
2. Release the two tumble screws.
3. Fully pull out carefully the PEM insertion lever.
4. Pull out the PEM.

4.3.9 Fan Tray Replacement

The shelf should be used only with fully-operational fan trays. A malfunctioning fan tray should be replaced immediately, in order to prevent thermal damage to the installed application cards.



Use care when handling the fan trays, and do not handle them from the connectors. Improper handling of the fan trays could cause damage to the connector pins.

Do not handle a fan tray while the fans are operating.

➔ **To replace the fan tray:**

1. Without interrupting power, release the two tumble screws on the front side of the fan tray.
2. Extract the tray by pulling at the handle, as shown below:
3. Insert the replaceable fan tray unit.
4. Push each of the two thumbscrews in and tighten.



Figure 22 – Shelf fan tray extraction

4.3.10 E²PROM Replacement

E²PROMs are generally installed and handled only in the factory. Follow the procedure below in the rare case that it becomes necessary to field replace the E²PROMs.

➔ **To replace an E²PROM:**

1. Without shutting down the system, remove the rear panel, near the two ground screws, by unscrewing the tumble screws.

2. Carefully remove the E²PROM boards (one, two or both).
3. Insert the new E²PROM into place. make sure it is inserted to the socket properly.
4. Refasten the rear panel using the tumble screws.

4.4 Handling Alarms

Both visual indicators and software alarms are provided.

4.4.1 Visual Alarms

Nine LEDs at the front of the Shelf Management card provide visual alarms.

LED Functions: General LEDs

LED	Status	Meaning
ACT	Green	Shelf manager is active
	Red	Shelf manager failure
	Blink	Shelf manager is inactive
PWR	Green	Local voltage supply on Shelf manager is good
	Off	Local voltage failure
HS (hot swap)	Steady Blue	Shelf manager is powering up or ready for extraction
	Blinking blue	Shelf manager hot swap process
	Off	Shelf manager is operating

Figure 23 – General LEDs

LED Functions: Telco Alarm LEDs

LED	Status	Meaning
CRT (Critical)	Off	Normal operation
	Red	System alarm event
MJR (Major)	Off	Normal operation
	Red	System alarm event
MNR (Minor)	Off	Normal operation
	Red	System alarm event

Figure 24 – Telco Alarm LEDs

Upon completion of boot-up, LEDs will display as follows:

General LEDs		Telco Alarm LEDs	Application Defined LEDs
ACT	return to normal state	OFF	OFF
PWR	Remains ON		
HS	Lights steady blue for a few seconds, then begins blinking, then goes off after a few blinks		

Figure 25 – LEDs status when Shelf Manager boot-up completely

4.4.2 Software Alarms

The FlexChassis ATCA-SH60 supports software alarms according to *PICMG Specifications 3.0*. Please refer to these specifications for a detailed description.

LED Functions: Application-Defined LEDs

LED	Status	Meaning
A	Green/ red/ bi-color	As defined by application
B	Green	As defined by application
C	Amber	As defined by application

Figure 26 – Application-Defined LEDs

4.5 Hot-Swapping FRUs

All the active components in the platform are mounted on (or housed in) field-replaceable units (FRUs) that you can easily remove and replace. The subrack, backplane, and other non-FRUs do not contain active components.

All FRUs are hot-swappable: you can remove and insert a FRU without shutting down any other shelf component. Hot swapping facilitates planned maintenance activities and FRU replacement.

The platform includes front-panel LEDs and a Telco alarm, which can be configured to activate when a hardware or software failure occurs. If an external alarm system is connected to the platform, it will also be activated for the alarm condition. The alarms alert an operator or technician to replace a failed FRU or perform some other maintenance operation.

The following procedures are to be used when modules are hot-swapped.

➔ To remove a module:

1. Partially open the module's right ejector latch to activate the module's hot-swap switch.

The module's IPMC sends to the Shelf Manager a request to deactivate, and the blue hotswap LED blinks at a fast rate.

2. The Shelf Manager determines whether the module can be extracted. If it can, the Shelf Manager grants permission to the IPMC.
3. The IPMC disables the interfaces that are controlled by electronic keying, and shuts down the module's operations. It then notifies the Shelf Manager the deactivation is complete. The blue LED remains lit.
4. Extract the module.
5. The Shelf Manager reclaims the module's power budget. Also, as part of electronic keying, the Shelf Manager disables—on other modules—the interfaces that are only shared with the deactivated module.

4.6 Resetting the System

One or both of the following reset options should be used if the shelf management board is not responding. (The second step should be performed only if the first one has not solved the problem.)

1. Press the Reset button on the Shelf Manager board front panel.
2. Extract the Shelf Manager board from the shelf, and re-insert it.

4.7 Troubleshooting

The following table summarizes potential problems and recommended solutions.

Problem	Probable cause	Solution
Shelf Manager board does not boot up properly: One or more of the LEDs fails to light during boot-up. The LEDs fail to return to their status as described in Section 4.4.1, above. The blue LED does not blink.	Shelf Manager board is not in fully inserted in the cage. Shelf Manager board failure.	Check that the Shelf Manager board is properly inserted in the cage; Verify that the ejector clip is closed. Replace Shelf Manager board.
Fans fail to operate at power up	Shelf Manager board improperly inserted in the chassis. Shelf Manager failure. Fan tray failure.	Replace Shelf Manager board. Replace fan tray.
Fan speed does not decrease after boot-up is completed	Shelf Manager board failure.	Replace board.
Fan tray LED is lit red	One or more of the fans are not working. Logic failure.	Pull the fan tray out for few seconds until all fans stop spinning, and re-insert it. Replace fan tray. Replace Shelf Manager board following this sequence: Insert a second Shelf Manager board in the redundant slot; Issue a switchover command to switch shelf control from the current Shelf Manager board to the redundant one; Extract the old Shelf Manager board.
Boot sequence does not complete, and the blue LED continues to blink after the Shelf Manager card has been replaced and all relevant monitor commands have been performed	One of the Backplane's connectors is damaged. One of the cage units, or the ATCA board, does not fit properly in the cage.	Replace E ² PROMs, if you have not yet done so; Replace chassis.

5 System Specifications

This chapter documents the product's standards certification, and physical and other technical specification parameters.

5.1 Certification

The FlexChassis ATCA-SH60 is targeted for NEBS level-3, FCC, UL and CE certification. It complies with the following standards:

- Advanced TCA, PICMG 3.x
- IPMI v 1.5.
- CP-TA B.4

5.2 Technical Data

The following table presents technical specifications for each of the product elements.

Category	Property	Description/Value
Physical		
	Number of slots	6 slot 8Ux280mm, front blades; 6 slot 80mm, RTMs
	Dimensions	265.8mm (6U) "H x 448mm (17.637")W (19" rack mount) x413.4mm (16.275")Depth Not including handles & cable holders
	EMI	EMI gasketing and hardware spacing to support FCC part B
	Weight	18Kg
	Compliance	PICMG 3.0; R.2.0
	Temperature	Humidity: 5% to 95%, non-condensed Storage Temperature: -40° to +70° Celsius Operating Temperature: -5° to +55° Celsius
	Other	Front and rear ESD jack Front rack flanges Front cable management tray
Accessibility		
	Front	Shelf Manager, Fan Tray, Front boards, Air Filter Tray, Power Supplies
	Rear	RTMs, PEMs
Backplane		
	Bus Architecture	Up to six third-party ATCA-compliant front boards, Dual star, bussed IPMB, dual redundant Shelf Manager boards
	Signal bandwidth rating	Supports up to 3.125Gbps per differential pair
	Base interface	Base channel interconnect between six ATCA slots, with support for 10/100/1000 BASE-T Ethernet; base channel 1 is allocated to Shelf Manager
	Fabric interface	Fabric channel interconnect between six ATCA slots
	Hub/Node slots	2 logical slots 1 & 2 Hub/Node configuration
	Update channels	Update channel between slots 1&2 and 3&4 and 5&6
Power		
	AC Power Supply	Front redundant, self cooled, hot swappable, integral power supply. Input power 100 – 240 VAC.
	DC PEMs	Rear redundant, hot swappable, integral PEM, input power 40-72VDC
Cooling		
	Number of fan trays	Front hot-pluggable fan tray with 10, N+1, axial fans for front and RTM slots
	Redundancy per fan tray	N+1 (i.e., any one fan can fail with no service degradation)
	Fan speed	Variable speed under shelf manager board control
	Cooling capacity	Total bulk airflow of 548cfm
Alarm I/O		
	Electrical/Mechanical Placement	Dual redundant Alarm I/O Modules accessible from front of shelf
	Alarm I/O interfaces	15-pin DA-15P connector. Supports 4 outputs (Major, Minor, Critical, Power) and 2 inputs (Major & Minor Reset)
Regulatory		
	Safety	Certified for UL. Designed to meet CE, TUV requirements
	EMC	Designed to meet CE & FCC part 15 requirements
	Environment	Designed to be Compatible with NEBS level-3 and ETSI
Other		

Shelf Identity

Configuration board with on-board E²PROM stores shelf serial number, part number, backplane routing assignments, shelf heat budget and other data.

5.3 Acronyms Used in this Manual

Acronym	Meaning
ATCA	Advanced Telecom Computing Architecture
FRU	Field-Replaceable Unit
HS	Hot swap
PEM	Power Entry Module
IPMB	Intelligent Platform-Management Bus
IPMI	Intelligent Platform-Management Interface
RTM	Rear Transmission Module
NEBS	Network Equipment-Building Systems
Shelf Manager	Shelf Manager board
ETSI	European Telecommunications Standards Institute
ANSI	American National Standards Institute
CE	"Conformité Européene" ("European Conformity")
PS	Power Supply
FCC	Federal Communications Commission
UL	Underwriters Laboratories - safety standards
CFM	Cubic Feet per Minute – Airflow measurement unit
